

# Apricus 30 tube collector

## Product Specifications Sheet



### Overview

Apricus solar collectors use high efficiency twin-glass evacuated tubes to absorb solar energy and convert it into usable heat. Freeze protected heat pipes transfer heat from within the evacuated tube up to an insulated copper header pipe through which a heat transfer liquid is circulated.

Suitable for domestic or commercial applications, Apricus solar collectors maintain strong efficiency levels even at high delta-t temperatures. For this reason Apricus collectors are ideal for cold regions and high temperature applications.

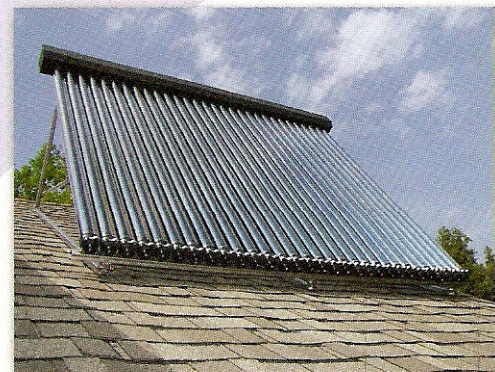

### Physical Specifications

Overall Length	1980mm / 80"
Overall Height	156mm / 6.14"
Overall Width	2196mm / 86.4"
Absorber Area	2.4m <sup>2</sup> / 25.8ft <sup>2</sup>
Aperture Area	2.82m <sup>2</sup> / 30.3ft <sup>2</sup>
Gross Area	4.35m <sup>2</sup> / 46.8ft <sup>2</sup>
Gross Dry Weight	95kg / 209lb
Fluid Capacity	710ml / 24fl oz
Max Operating Pressure	800kPa / 116psi
Stagnation Temperature	< 220°C / 432°F

### Performance Variables (aperture area)

Eta0 (y-intercept)	0.656
a1 [W/(m <sup>2</sup> K)]	1.4*
a2 [W/(m <sup>2</sup> K <sup>2</sup> )]	0.007*
Heat Capacity [kJ/(m <sup>2</sup> /K)]	44.89
Peak Power Output	1850W / 6312Btu

### Key Material Specifications

Evacuated Tubes	Borosilicate 3.3 Glass
Overall Length	Al-N on Al on Glass
Heat Pipes	High Purity Copper
Heat Transfer Fins	Aluminum
Rubber Components	HTV Silicone Rubber
Mounting Frame	439 Stainless Steel
Manifold Casing	H16 Aluminum

### Installation Guidelines

Max Flow Rate	15L/min / 3.9gpm
Max Tubes in Series	150 tubes
Install Angle Range	20-70°

\* Performance values internally verified

### Internationally Certified Product

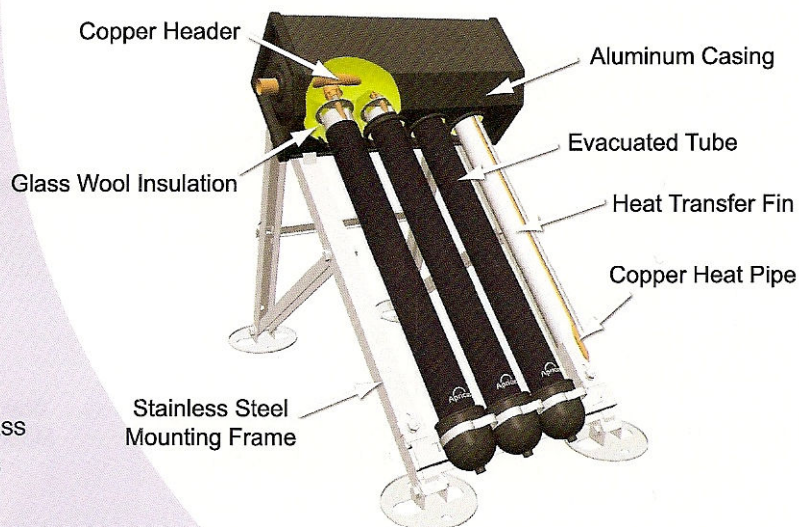

Available Through:



For more information, visit us online at [www.apricus.com](http://www.apricus.com)